

SPINDLE MOTOR DRIVER

The KA3020D is a monolithic integrated circuit, suitable for a 3-phase spindle motor drive of a CD system.

FEATURES

- 3-phase, full-wave, linear BLDC motor driver
- Power save at stop mode
- Built-in current limiter
- Built-in TSD (thermal shutdown) circuit
- Built-in 3X or 1X hall FG output
- Built-in hall bias circuit
- Built-in rotational direction detector
- Built-in reverse rotation preventer
- Built-in short braker
- Corresponds to 3.3 V or 5 V DSP

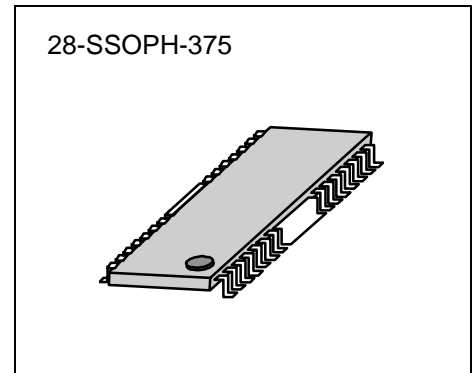

ORDERING INFORMATION

Device	Package	Operating Temperature
KA3020D	28-SSOPH-375	-25°C ~ +75 °C

BLOCK DIAGRAM

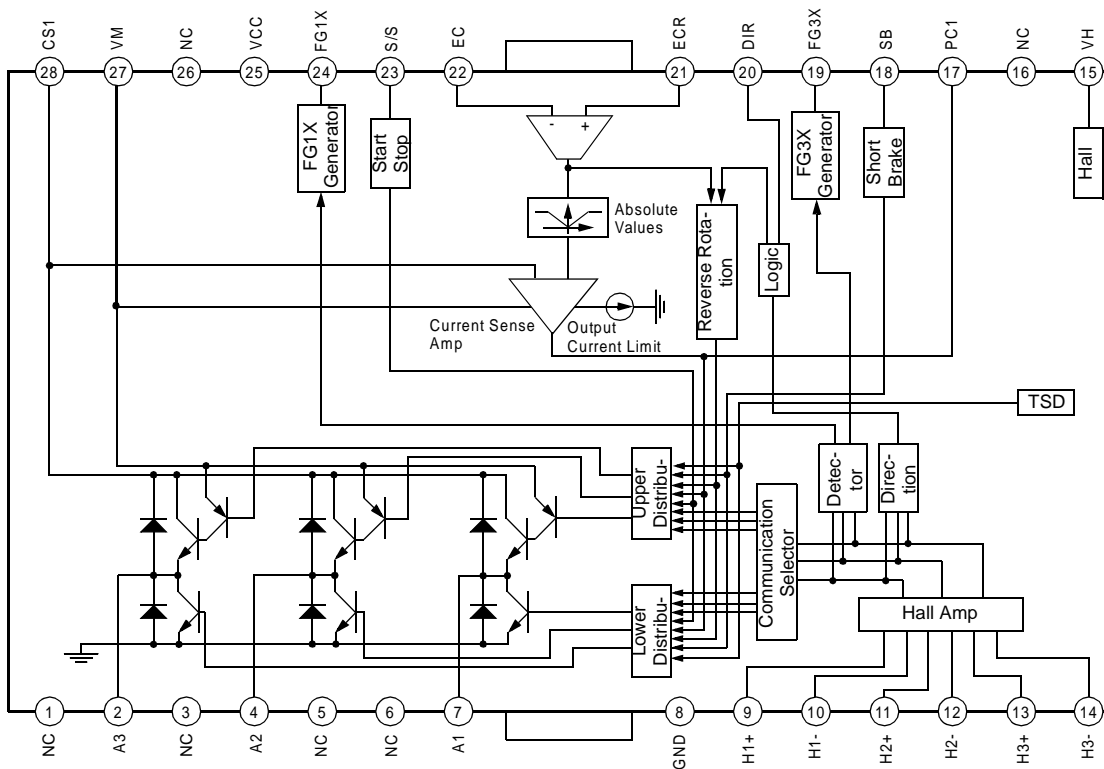

PIN CONFIGURATION

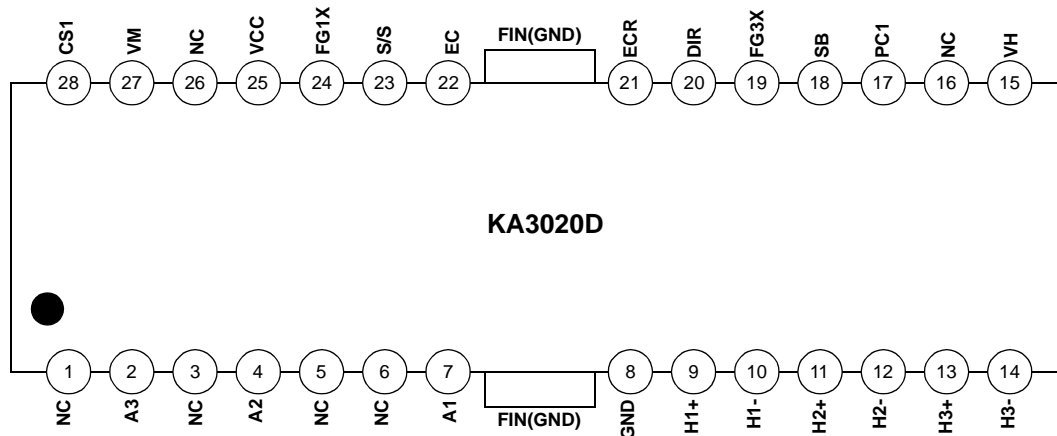

PIN DESCRIPTIONS

Pin no.	Symbol	I/O	Description	Pin no.	Symbol	I/O	Description
1	NC	-	No connection	15	VH	I	Hall bias
2	A3	O	Output (A3)	16	NC	-	No connection
3	NC	-	No connection	17	PC1	-	Phase compensation capacitor
4	A2	O	Output (A2)	18	SB	I	Short brake
5	NC	-	No connection	19	FG3X	O	FG waveform (3X)
6	NC	-	No connection	20	DIR	O	Rotational direction output
7	A1	O	Output (A1)	21	ECR	I	Output current control reference
8	GND	-	Ground	22	EC	I	Output current control voltage
9	H1+	I	Hall signal (H1+)	23	S/S	I	Power save (Start/Stop switch)
10	H1-	I	Hall signal (H1-)	24	FG1X	O	FG waveform (1X)
11	H2+	I	Hall signal (H2+)	25	VCC	-	Supply voltage (Signal)
12	H2-	I	Hall signal (H2-)	26	NC	-	No connection
13	H3+	I	Hall signal (H3+)	27	VM	-	Supply voltage (Motor)
14	H3-	I	Hall signal (H3-)	28	CS1	-	Output current detection

EQUIVALENT CIRCUITS

HALL INPUT	DRIVER OUTPUT
TORQUE CONTROL INPUT	HALL BIAS INPUT
START/STOP INPUT	SHORT BRAKE INPUT
DIR or FG OUTPUT	

ABSOLUTE MAXIMUM RATINGS (TA=25°C)

Characteristics	Symbol	Value	Unit
Maximum supply voltage (Signal)	V_{CCmax}	7	V
Maximum supply voltage (Motor)	V_{Mmax}	18	V
Power dissipation	P_d	1.7 _{note}	W
Maximum output current	I_{Omax}	1.3	A
Operating temperature range	T_{opr}	-25 ~ +75	°C
Storage temperature range	T_{stg}	-55 ~ +150	°C

- Note: 1. When mounted on 50mm × 50 mm × 1mm PCB (Phenolic resin material)
 2. Power dissipation is reduced 13.6 mW/°C for using above Ta=25°C
 3. Do not exceed Pd and SOA(Safe operating area).

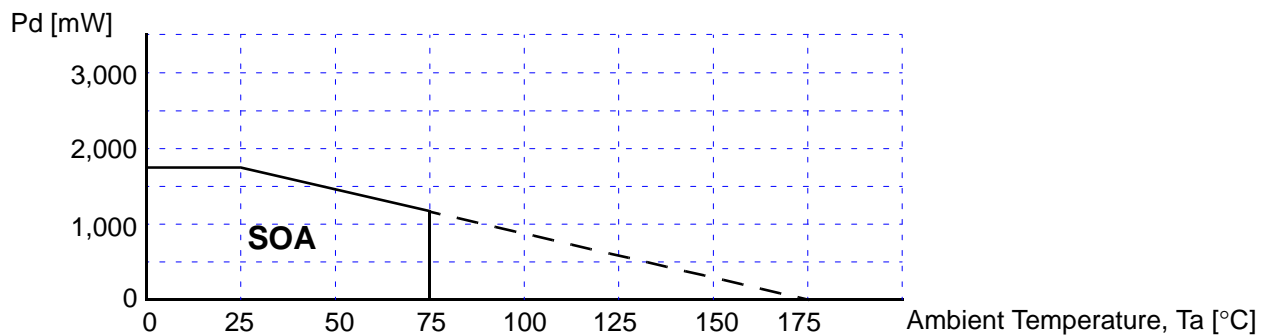
**RECOMMENDED OPERATING CONDITIONS**

Characteristics	Symbol	Value			Unit
		Min.	Typ.	Max.	
Supply Voltage	V_{cc}	4.5	5	5.5	V
Motor Supply Voltage	V_M	3.5	12	15	V

ELECTRICAL CHARACTERISTICS(Unless otherwise specified, $T_a = 25\text{ }^\circ\text{C}$, $V_{cc}=5\text{ V}$, $V_M=12\text{ V}$)

Characteristics	Symbol	Condition	SPEC			Unit
			Min.	Typ.	Max.	
Quiescent circuit current	Icc		2	5	8	mA
START/STOP						
On voltage range	Vsson	Output driver ON	2.5	-	Vcc	V
Off voltage range	Vssoff	Output driver OFF	0.0	-	1.0	V
HALL BIAS						
Hall bias voltage	Vhb	Ihb=20 mA	0.4	1.0	1.8	V
HALL AMP						
Hall bias current	Iha		-	0.5	2	uA
Common-mode input range	Vhar		1.5	-	4.0	V
Minimum input level	Vinh		60	-	-	mVpp
TORQUE CONTROL						
Ecr Input voltage range	Ecr		0.2	-	4.0	V
Ec Input voltage range	Ec		0.2	-	4.0	V
Offset voltage (-)	Ecoff-	Ec=2.5 V	-80	-50	-20	mV
Offset voltage (+)	Ecoff+	Ec=2.5 V	20	50	80	mV
Ec Input current	Ecin	Ec=2.5 V	-5	0.5	5	uA
Ecr Input current	Ecrin	Ecr=2.5 V	-5	0.5	5	uA
Input/output gain	Gec	Ec=2.5 V, Rcs=0.5 Ω	0.41	0.51	0.61	A/V
FG						
FG output voltage (H)	Vfgh	I _{fg} =-10 uA	3.0	-	Vcc	V
FG output voltage (L)	Vfgl	I _{fg} =10 uA	-	-	0.5	V
Duty (reference value)			-	50	-	%
OUTPUT BLOCK						
Saturation voltage (upper TR)	Voh	I _o =-300 mA	-	0.9	1.6	V
Saturation voltage (lower TR)	Vol	I _o =300 mA	-	0.2	0.6	V
Torque limit current	I _{tl}	Rcs=0.5 Ω	560	700	840	mA

Characteristics	Symbol	Condition	SPEC			Unit
			Min.	Typ.	Max.	
DIRECTION DETECTOR						
DIR output voltage (H)	Vdirh	I _{fg} =-10 μ A	3.0	-	V _{cc}	V
DIR output voltage (L)	Vdirl	I _{fg} =10 μ A	-	-	0.5	V
SHORT BRAKE						
ON voltage range	Vsbon		3.5	-	V _{cc}	V
OFF voltage range	Vsboff		0	-	1.0	V

APPLICATION INFORMATION

1. TORQUE CONTROL & OUTPUT CURRENT CONTROL

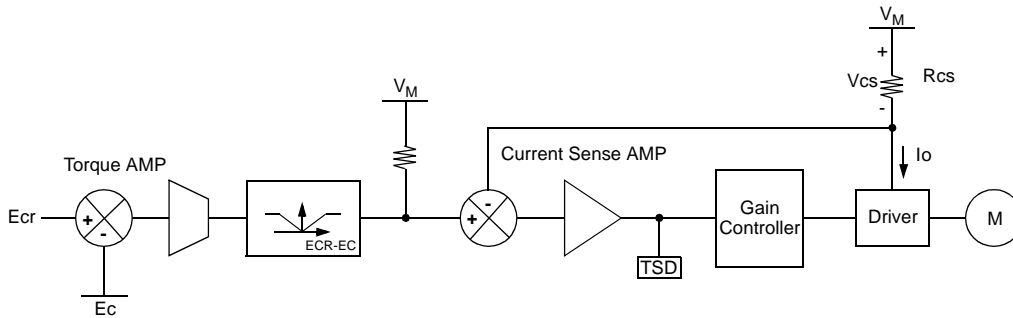

- 1) By amplifying the voltage difference between E_c and E_{cr} from Servo IC, the Torque Sense AMP produces the input (V_{AMP}) for the Current Sense AMP.
- 2) The output current (I_O) is converted into the voltage (V_{CS}) through the sense resistor (R_{CS}) and compared with the V_{AMP} . By the negative feedback loop, the sensed output voltage, V_{CS} is equal to the input V_{AMP} . Therefore, the output current (I_O) is linearly controlled by the input V_{AMP} .
- 3) As a result, the signals, E_C and E_{CR} can control the velocity of the Motor by controlling the output current (I_O) of the Driver.
- 4) The range of the torque voltage is as shown below.

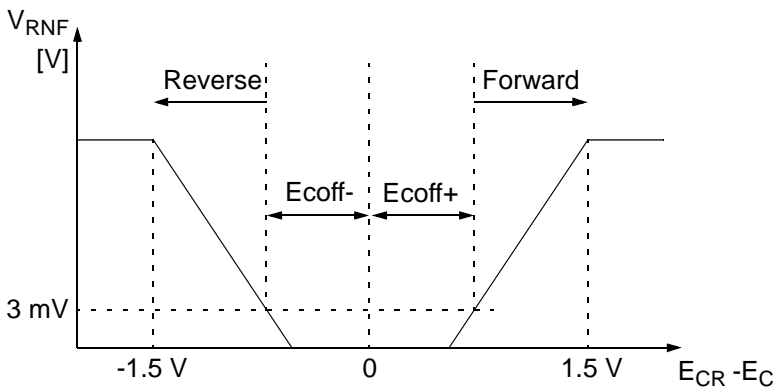

	Rotation
$E_{CR} > E_C$	Forward rotation
$E_{CR} < E_C$	Stop after detecting reverse rotation

The input range of E_{CR} , E_C is 0.2 V ~ 4 V

2.SHORT BRAKE

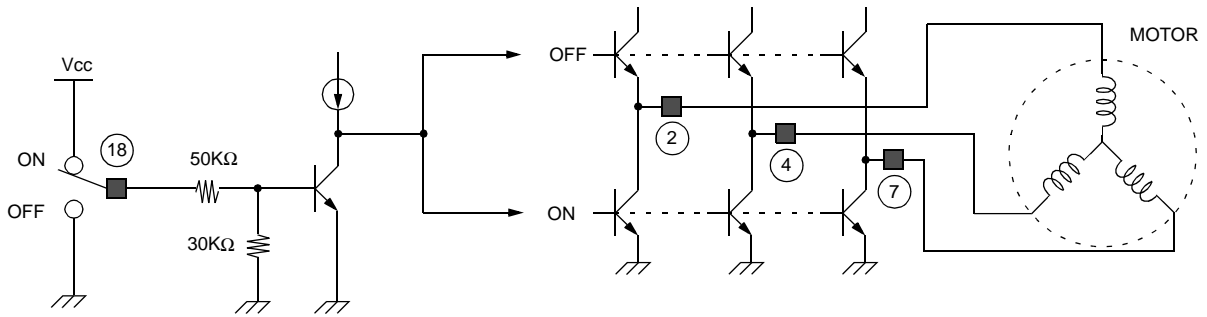

Pin # 18	Short Brake
HIGH	ON
LOW	OFF

When the pick-up part moves from the inner to the outer spindle of the CD, the Brake function of the reverse voltage is commonly employed to decrease the rotating velocity of the Spindle Motor. However, if the Spindle Motor rotates rapidly, the Brake function of the reverse voltage may produce much heat at the Drive IC. To remove this shortcoming and to enhance the braking efficiency, the Short Brake function is added to KA3020D. When the Short Brake function is active, all upper Power TRs turn off and all lower Power TRs turn on, so as to make the rotating velocity of the Motor slow down. But FG and DIR functions continue to operate normally.

3. START/STOP (POWER SAVE)

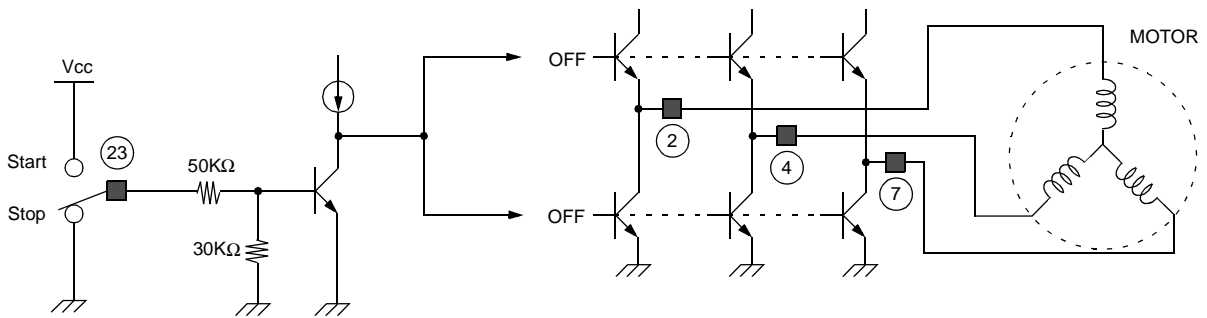

Pin # 23	Start/Stop
HIGH	OPERATE
LOW	STOP

When Start/Stop function active, all Power TRs turn off but FG and DIR functions continue to operate normally.

4. TSD (THERMAL SHUTDOWN)

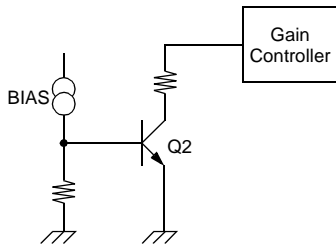

When the chip temperature rises up to about 175°C, the Q2 turns on so that the output driver will be shutdown. When the chip temperature falls off to about 150°C, then the Q2 turns off so that the driver is to operate normally. Thus, TSD has the temperature hysteresis of about 25°C.

5. ROTATIONAL DIRECTION DETECTION

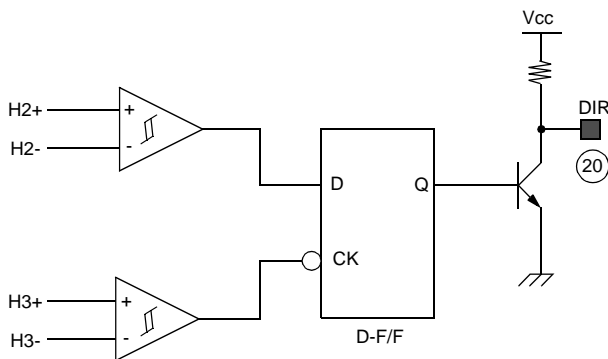

Rotation	Ⓜ DIR
Forward	Low
Reverse	High

- 1) The forward and the reverse rotations of the CD are simply detected by using the D-F/F and the truth table is shown in the above table.
- 2) The rotational direction of the CD can be explained by the output waveforms of the Hall sensors. Let the three outputs of Hall sensors be H1, H2 and H3 respectively. When the spindle rotates in reverse direction, the Hall sensor output waveforms are shown in Fig.(a). Thus the phases order in H1→H2→H3 with a 120° phase difference.

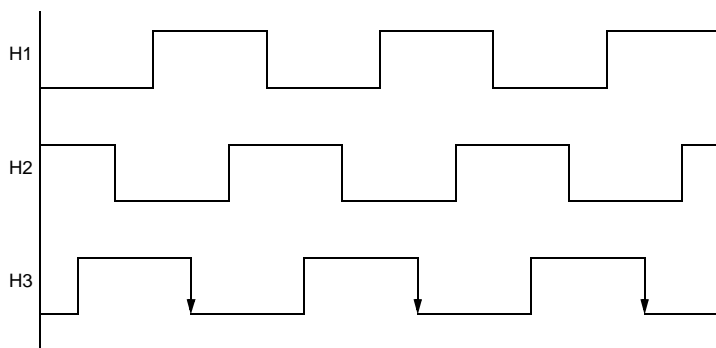

(a) Reverse rotation

On the other hand, if the spindle rotates in forward rotation, the phase relationship is H3→H2→H1 as shown in Fig.(b)

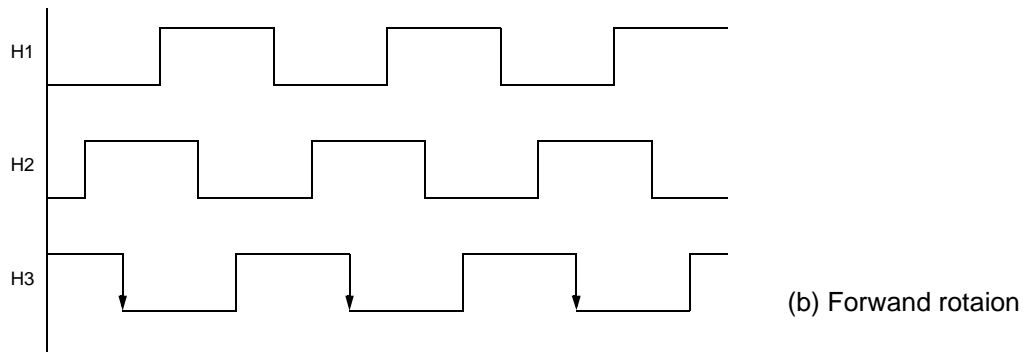

Therefore, the output of the rotational direction detector is Low, when the spindle rotates forward, while HIGH as in the case of the reverse rotation.

6.REVERSE ROTATION PREVENTION

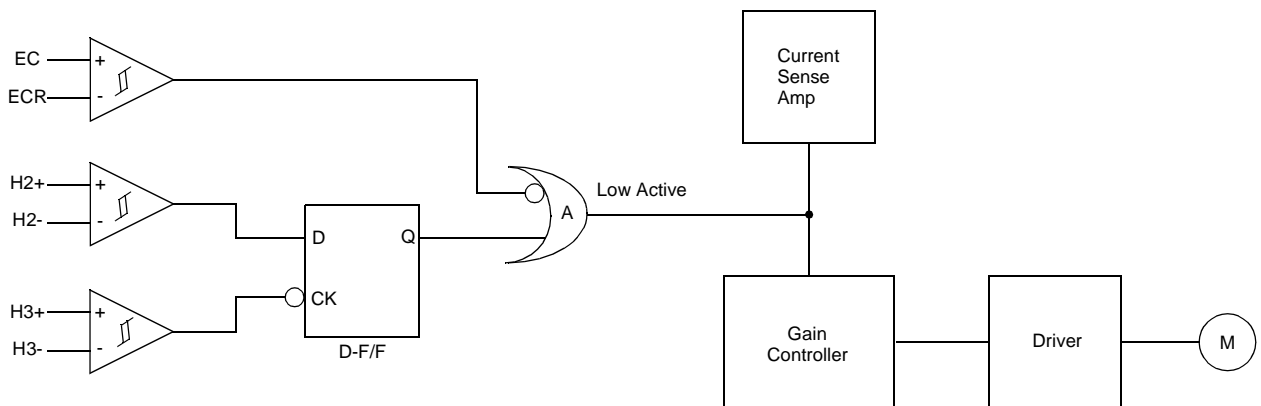

- 1) When the output of the OR Gate, A is LOW, it steers all the output current of the current sense Amp makes the current delivered to the Gain Controller zero. Thus the output current of the Driver becomes zero and the motor is stopped.
- 2) As in the state of the forward rotation, the D-F/F output, Q is HIGH and the motor rotates normally. At this state, if the control input is changed such that EC>ECR, then the motor rotates slowly more and more by the reverse commutation in the Driver. At the moment that the motor rotates in reverse direction, the D-F/F output becomes Low and the OR Gate output, thus, becomes LOW. This prevents the motor from rotating in reverse direction. The operation principle is shown in the table and the flow chart.

Rotation	H2	H3	D-F/F (Q)	Reverse Rotation Preventer	
				$E_C > E_{CR}$	$E_C > E_{CR}$
Forward	H	H→L	H	Forward	-
Reverse	L	H→L	L	-	Brake and Stop

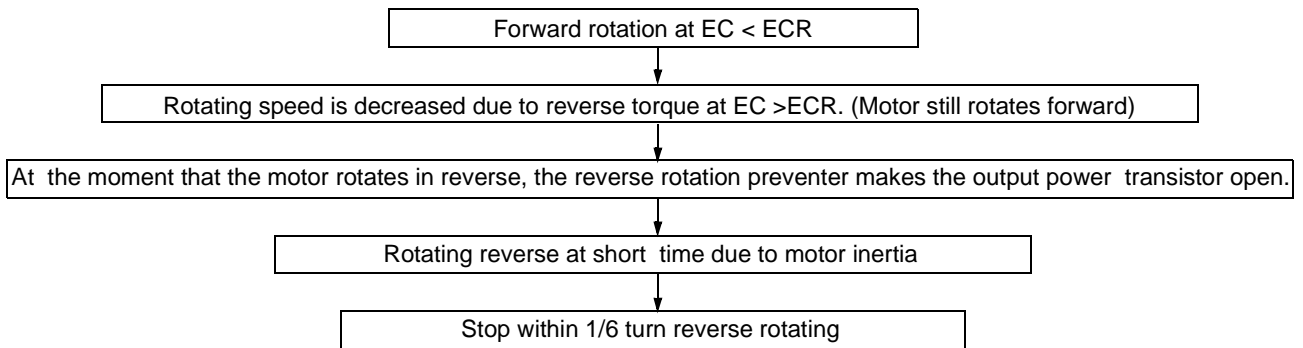

7. FG OUTPUT

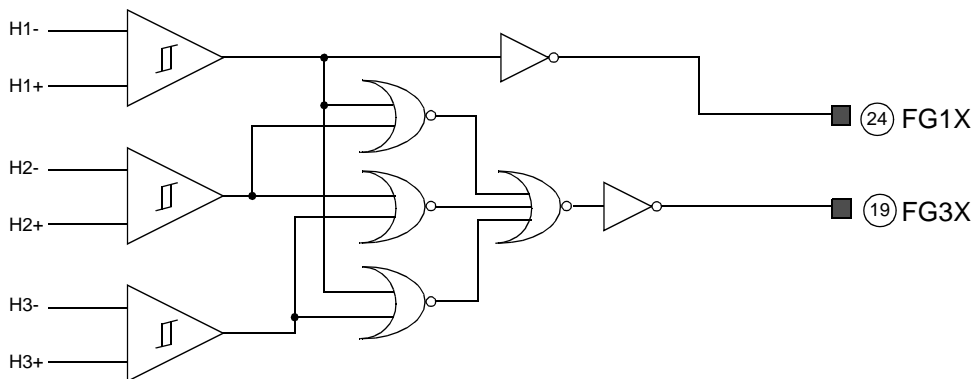

8. HALL SENSOR CONNECTION

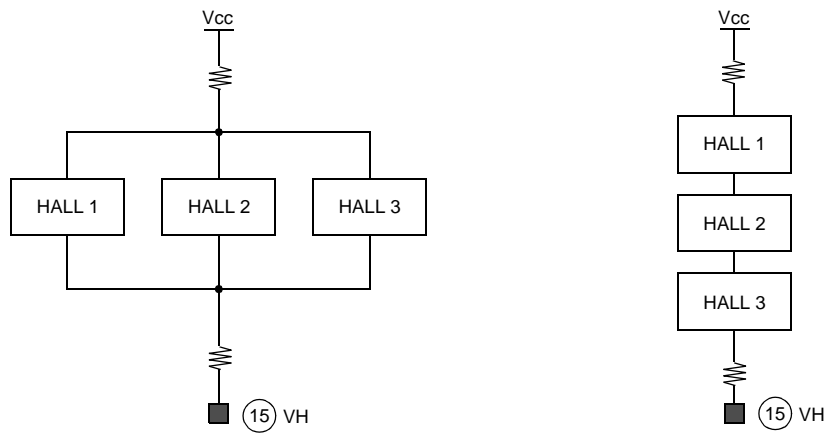
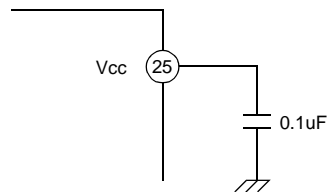
9. CONNECT A BY-PASS CAPACITOR, 0.1 μ F BETWEEN THE SUPPLY VOLTAGE SOURCE.10. THE HEAT RADIATION FIN IS CONNECTED TO THE INTERNAL GND OF THE PACKAGE.
CONNECT THAT FIN TO THE EXTERNAL GND.

11.INPUT-OUTPUT TIMING CHART

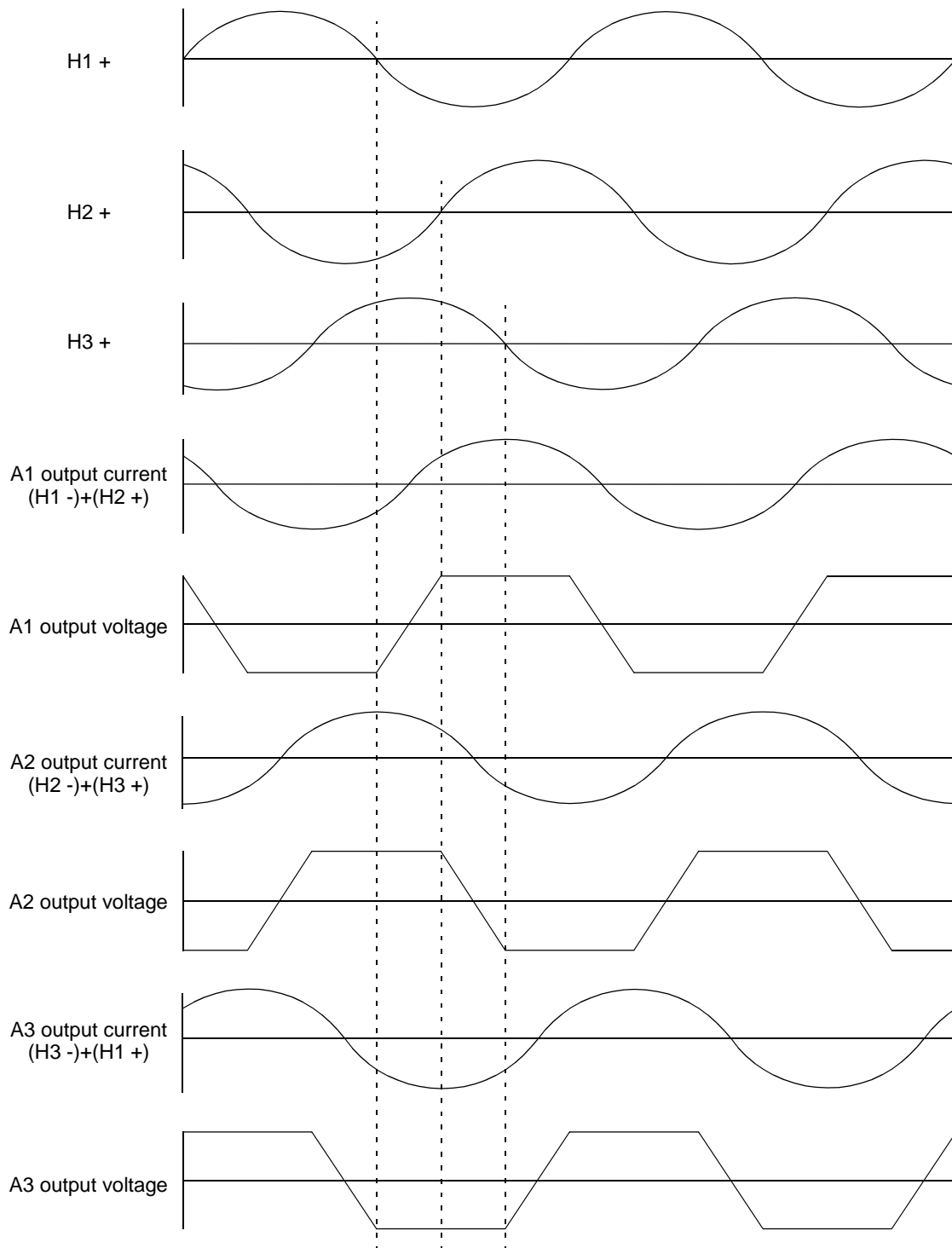

TEST CIRCUITS

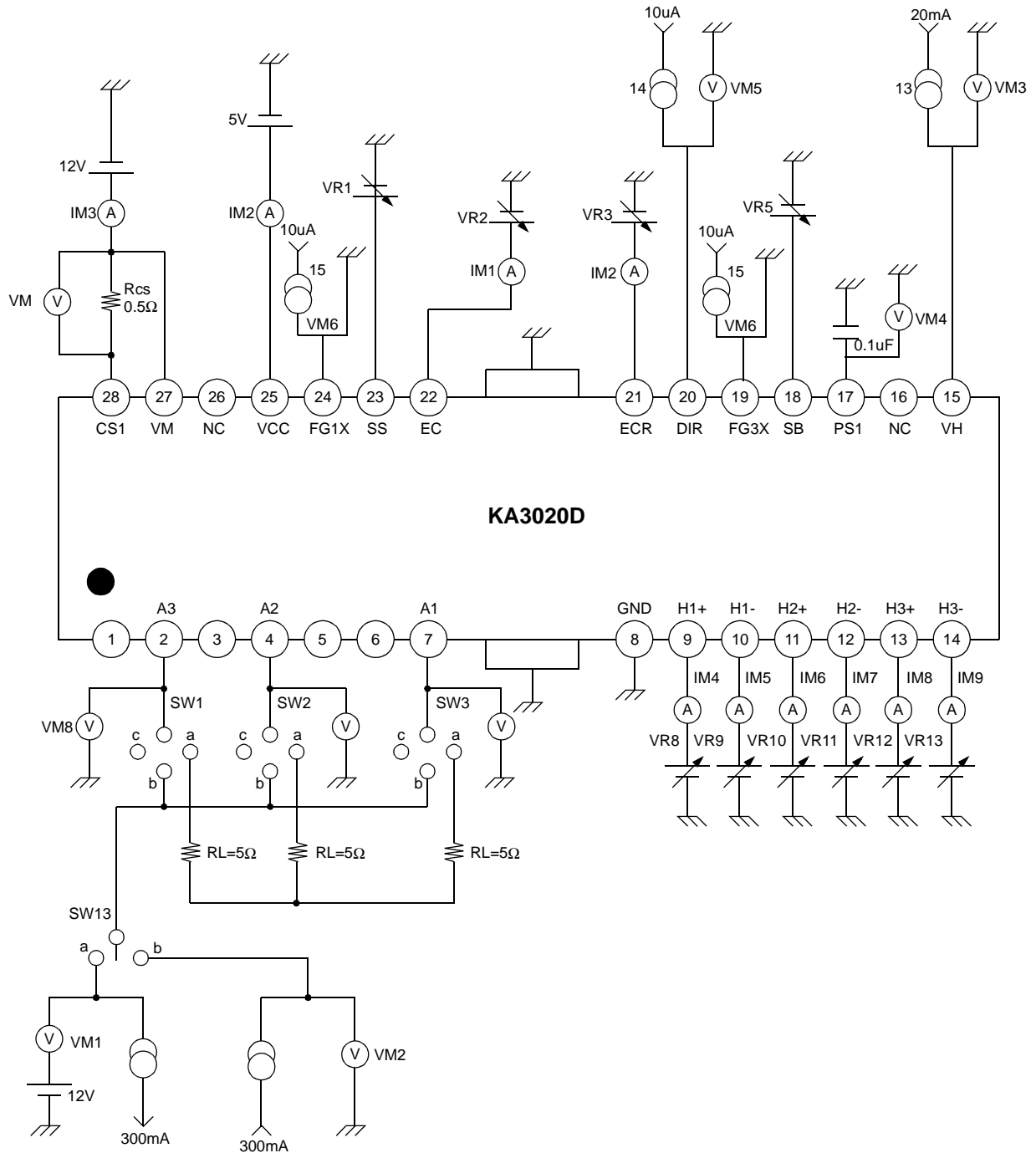

TYPICAL APPLICATION

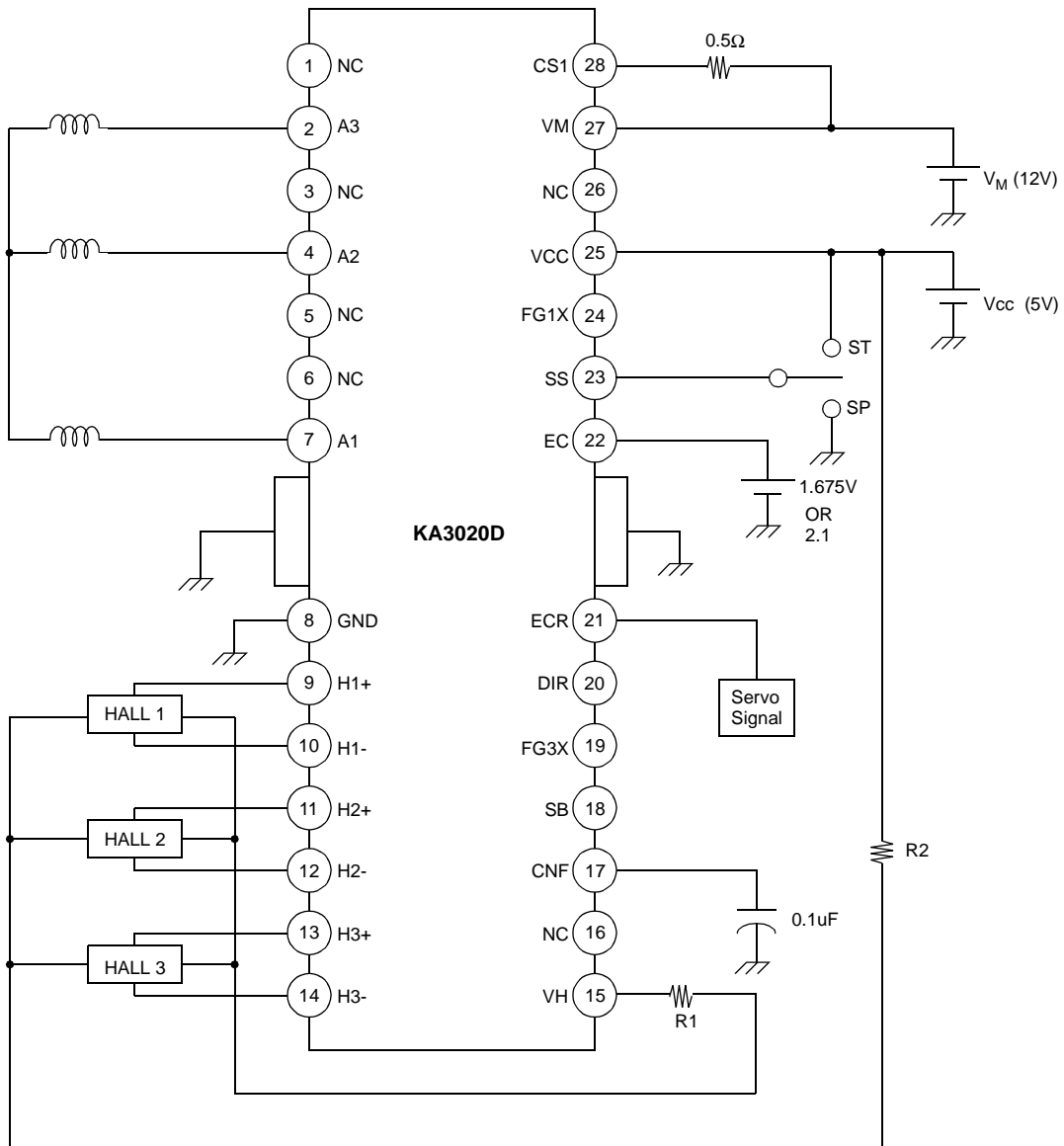

PACKAGE DIMENSION

28-SSOPH-375

